

GN 60

Button-type magnets

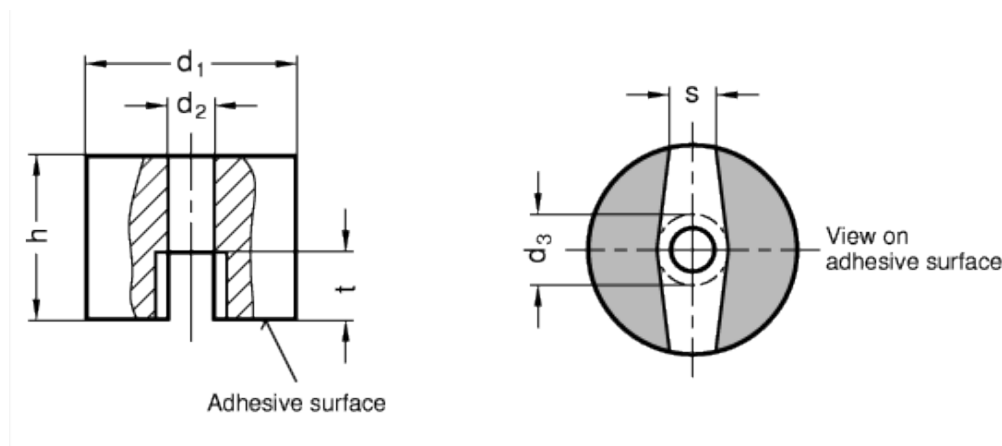

technical informations

Material of the magnet

Aluminium, nickel, cobalt AlNiCo AN, temperature resistant up to 280°C

Lacquering red, temperature resistant up to 180° C

Features and applications

The button-type magnets GN 60 have a split adhesive surface. These are non-shielded magnetic systems made by casting method.

To ensure that the magnetic properties (adhesive forces) are not impaired, the fixing screws must be made of non-magnetic material (magnetically non-conductive).

For easier handling and/or to avoid demagnetisation, these magnets have an iron plate on their adhesive surface.

Standard Elements	Main dimensions							Nominal adhesive forces	Weig
	Description	d ₁ Nominal dimension	Actual dimension	d ₂	d ₃ max. Ø screw head	h	s		
GN 60-AN-13	13	13	4.5	7	10	4.5	5	7	6
GN 60-AN-19	19	19.1	4.8	8.7	12.7	5.7	6.5	19	23

GN 60-AN-25	25	25.4	4.5	8.5	20	5.6	8	40	71
GN 60-AN-32	32	31.8	7.1	10	25.4	7.9	12.7	66	132



STANDARD MACHINE ELEMENTS WORLDWIDE